

SBO20AA277-1 S=0 D=0

MODIFICATION						NAME	TOLERANCE	DRAWN	CHECKED	APPROVED	DATE
						20 LEAD SIDE BRAZED PACKAGE	UNLESS OTHERWISE SPECIFIED	S.F	S.T	K.M	APR.4.'92
						SCALE 5/1	±.005		T.A		
						MATERIAL AS INDICATED	THIRD ANGLE PROJECTION				
	CHANGED		DATE	DRAWN	CHECKED	APPROVED	KYOCERA	KYOCERA CORPORATION		DRAWING NO.	SHEET
								KYOTO JAPAN	KD-S92277	1/2	

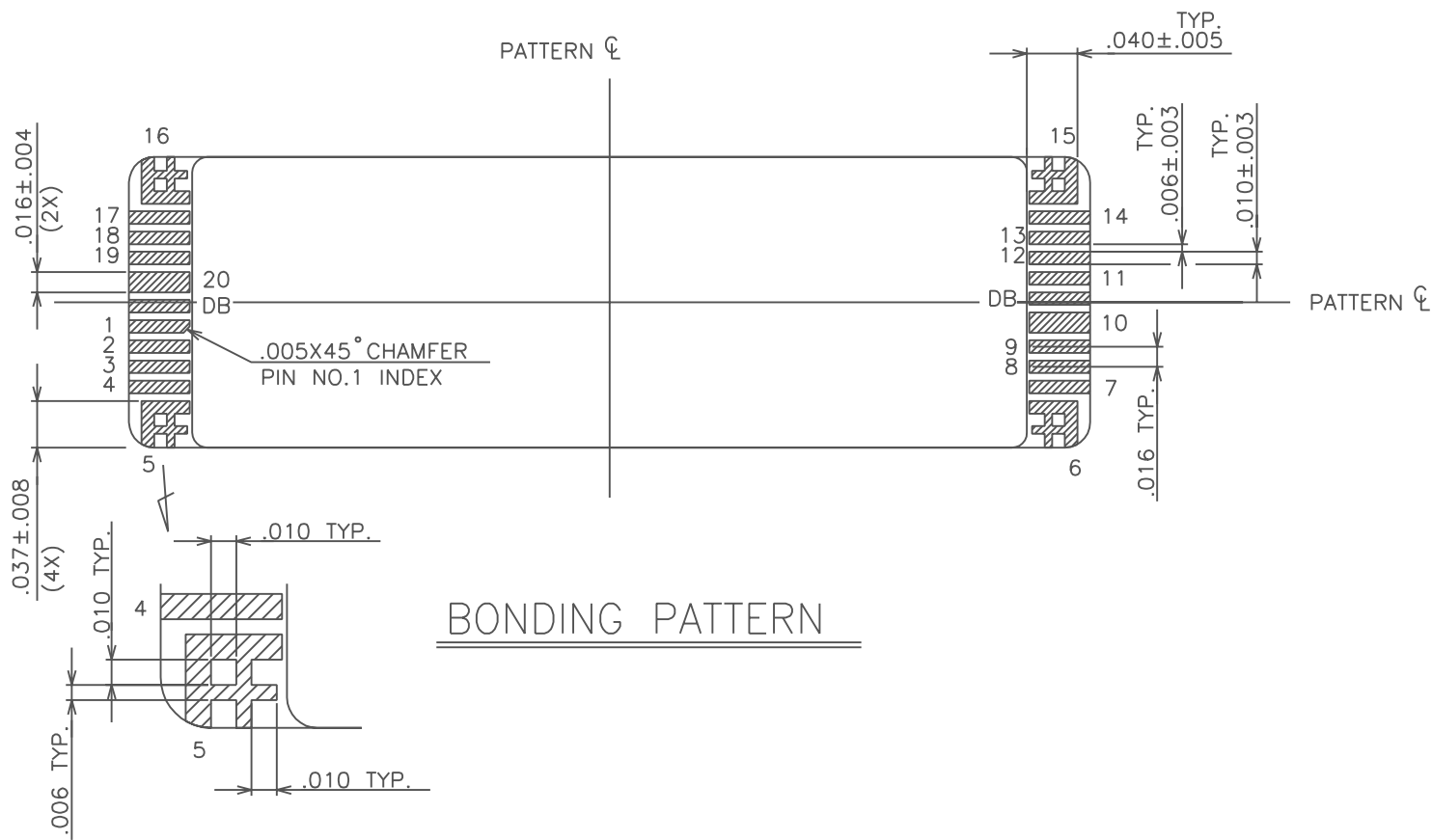

BONDING PATTERN

MODIFICATION						NAME	TOLERANCE	DRAWN	CHECKED	APPROVED	DATE
						20 LEAD SIDE BRAZED PACKAGE	UNLESS OTHERWISE SPECIFIED	S.F	S.T	K.M	APR.4.'92
						SCALE 10/1	MATERIAL		T.A		
							THIRD ANGLE PROJECTION				
	CHANGED	DATE	DRAWN	CHECKED	APPROVED	 KYOCERA CORPORATION KYOTO JAPAN	DRAWING NO.			SHEET	
							KD-S92277			2/2	