

BONDING PATTERN

|              |         |      |       |         |          |                                     |   |                          |                     |                  |                    |
|--------------|---------|------|-------|---------|----------|-------------------------------------|---|--------------------------|---------------------|------------------|--------------------|
| MODIFICATION |         |      |       |         |          | NAME<br>40 LEAD SIDE BRAZED PACKAGE | TOLERANCE<br>UNLESS OTHERWISE SPECIFIED | DRAWN<br>T.S/H.K         | CHECKED<br>A.F/S.NI | APPROVED<br>H.SA | DATE<br>SEP.11.'01 |
|              |         |      |       |         |          | SCALE 10/1                          | MATERIAL                                |                          |                     |                  |                    |
|              |         |      |       |         |          |                                     | THIRD ANGLE PROJECTION                  |                          |                     |                  |                    |
|              | CHANGED | DATE | DRAWN | CHECKED | APPROVED |                                     | KYOCERA CORPORATION<br>KYOTO JAPAN      | DRAWING NO.<br>KD-SA1E19 | SHEET<br>2/5        |                  |                    |

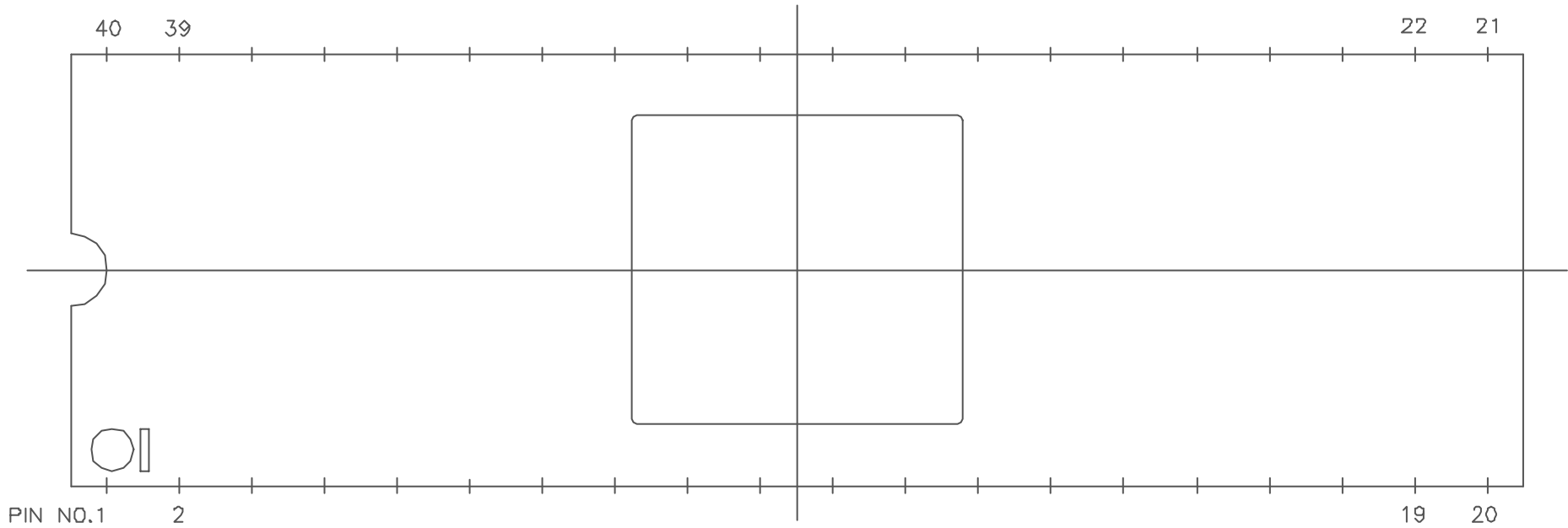

SSM P/N CSB04069



MP-1

|              |         |      |       |         |          |                             |                                    |                          |          |              |            |
|--------------|---------|------|-------|---------|----------|-----------------------------|------------------------------------|--------------------------|----------|--------------|------------|
| MODIFICATION |         |      |       |         |          | NAME                        | TOLERANCE                          | DRAWN                    | CHECKED  | APPROVED     | DATE       |
|              |         |      |       |         |          | 40 LEAD SIDE BRAZED PACKAGE | UNLESS OTHERWISE SPECIFIED         | T.S/H.K                  | A.F/S.NI | H.SA         | SEP.11.'01 |
|              |         |      |       |         |          | SCALE 7/1                   | MATERIAL                           |                          |          |              |            |
|              |         |      |       |         |          |                             |                                    | THIRD ANGLE PROJECTION   |          |              |            |
|              | CHANGED | DATE | DRAWN | CHECKED | APPROVED | KYOCERA                     | KYOCERA CORPORATION<br>KYOTO JAPAN | DRAWING NO.<br>KD-SA1E19 |          | SHEET<br>3/5 |            |



# SSM P/N CSB04069

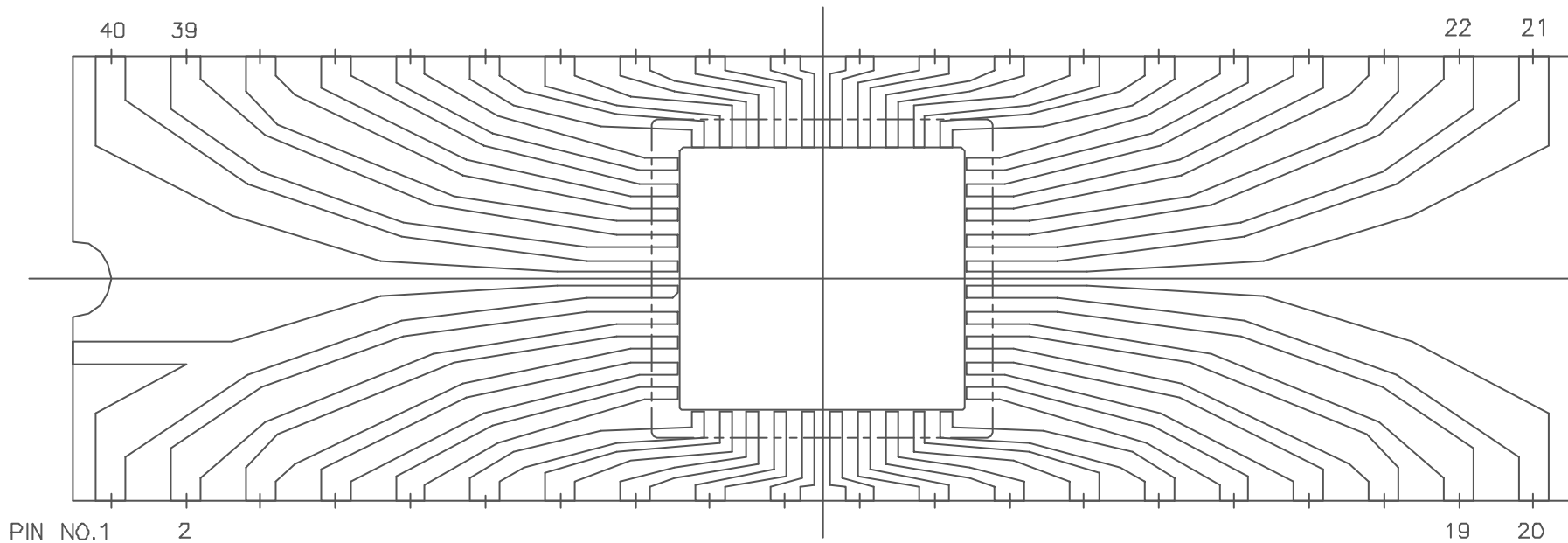

MP-2

|              |         |      |       |         |          |                             |                                    |             |         |           |              |
|--------------|---------|------|-------|---------|----------|-----------------------------|------------------------------------|-------------|---------|-----------|--------------|
| MODIFICATION |         |      |       |         | NAME     | 40 LEAD SIDE BRAZED PACKAGE | TOLERANCE                          | DRAWN       | CHECKED | APPROVED  | DATE         |
|              |         |      |       |         | SCALE    | 7 / 1                       | UNLESS OTHERWISE SPECIFIED         | T.S/H.K     | AF/S.NI | H.SA      | SEP.11.'01   |
|              |         |      |       |         |          | MATERIAL                    |                                    |             |         |           |              |
|              |         |      |       |         |          |                             | THIRD ANGLE PROJECTION             |             |         |           |              |
|              | CHANGED | DATE | DRAWN | CHECKED | APPROVED |                             | KYOCERA CORPORATION<br>KYOTO JAPAN | DRAWING NO. |         | KD-SA1E19 | SHEET<br>4/5 |



www.spectrum-semi.com Phone: 408.435.5555 Fax: 408.435.8226

SSM P/N CSB04069

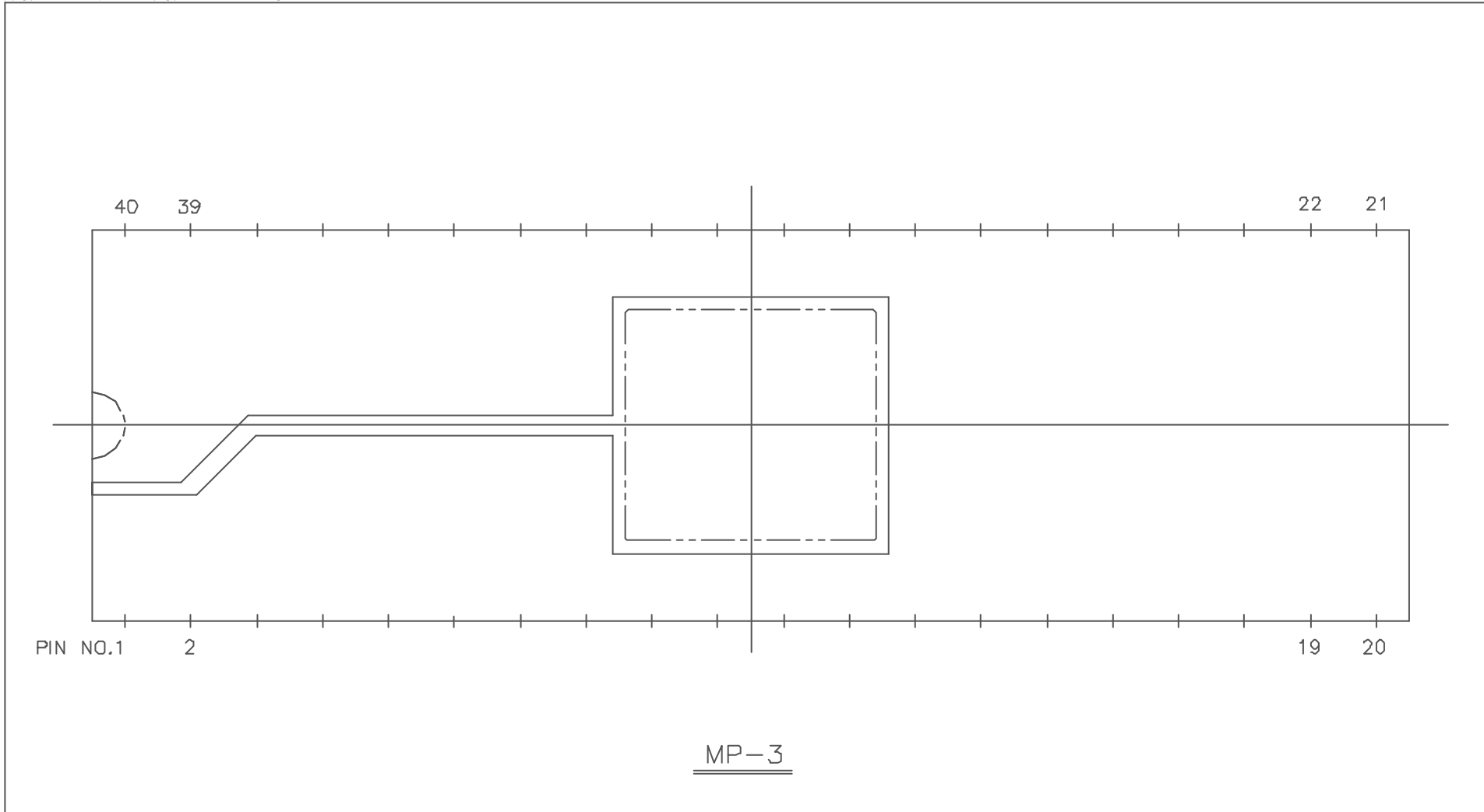

MP-3

|              |         |      |       |         |          |                                     |   |                   |                      |                  |                    |
|--------------|---------|------|-------|---------|----------|-------------------------------------|---|-------------------|----------------------|------------------|--------------------|
| MODIFICATION |         |      |       |         |          | NAME<br>40 LEAD SIDE BRAZED PACKAGE | TOLERANCE<br>UNLESS OTHERWISE SPECIFIED | DRAWN<br>T.S./H.K | CHECKED<br>A.F./S.NI | APPROVED<br>H.SA | DATE<br>SEP.11.'01 |
|              |         |      |       |         |          | SCALE<br>7/1                        | MATERIAL                                |                   |                      |                  |                    |
|              |         |      |       |         |          |                                     | THIRD ANGLE PROJECTION                  |                   |                      |                  |                    |
|              | CHANGED | DATE | DRAWN | CHECKED | APPROVED | KYOCERA CORPORATION<br>KYOTO JAPAN  | DRAWING NO.<br>KD-SA1E19                | SHEET<br>5/5      |                      |                  |                    |