

DETAIL-B  
(3PLCS)

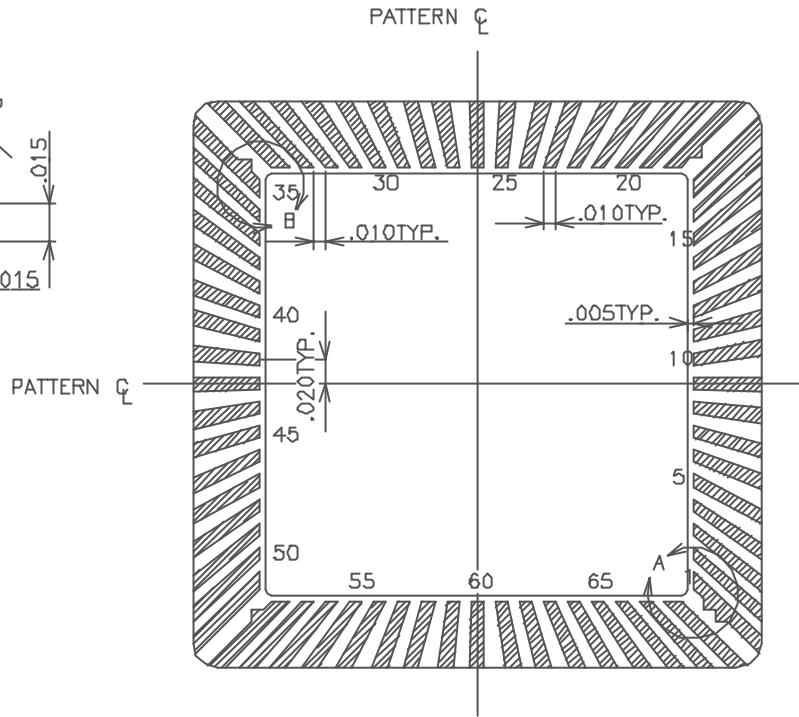

BONDING PATTERN

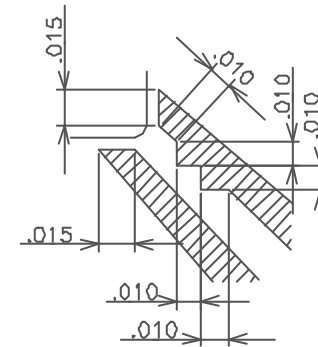

DETAIL-A

MODIFICATION						NAME 68 PIN GRID ARRAY PACKAGE	TOLERANCE UNLESS OTHERWISE SPECIFIED	DRAWN M.K	CHECKED M.S	APPROVED	DATE JUN.21.'94
						SCALE 10/1	MATERIAL				
	△	CONVERTED CAD DATA. CHANGED	MAR.30.98	E.K	H.S/S.N	T.A	THIRD ANGLE PROJECTION				
		DATE	DRAWN	CHECKED	APPROVED	KYOCERA CORPORATION KYOTO JAPAN		DRAWING NO. KD-84403-A		SHEET 2/3	

WIRE BOND PAD / CONNECTOR PIN INTERCONNECTION PLAN

W/B NO.	PIN NO.	W/B NO.	PIN NO.	W/B NO.	PIN NO.	W/B NO.	PIN NO.
1	B2	21	L3	41	G10	61	A6
2	B1	22	K4	42	G11	62	B5
3	C2	23	L4	43	F10	63	A5
4	C1	24	K5	44	F11	64	B4
5	D2	25	L5	45	E10	65	A4
6	D1	26	K6	46	E11	66	B3
7	E2	27	L6	47	D10	67	A3
8	E1	28	K7	48	D11	68	A2
9	F2	29	L7	49	C10		
10	F1	30	K8	50	C11		
11	G2	31	L8	51	B11		
12	G1	32	K9	52	B10		
13	H2	33	L9	53	A10		
14	H1	34	L10	54	B9		
15	J2	35	K10	55	A9		
16	J1	36	K11	56	B8		
17	K1	37	J10	57	AB		
18	K2	38	J11	58	B7		
19	L2	39	H10	59	A7		
20	K3	40	H11	60	B6		

S/R	NC
D/A	NC

MODIFICATION						NAME 68 PIN GRID ARRAY PACKAGE	TOLERANCE UNLESS OTHERWISE SPECIFIED	DRAWN M.K	CHECKED M.S	APPROVED	DATE JUN.21.'84
						SCALE X	MATERIAL				
	△	CONVERTED CAD DATA. CHANGED	DATE MAR.30.'98	DRAWN E.K	CHECKED H.S/S.NI	APPROVED T.A		THIRD ANGLE PROJECTION			
							KYOCERA CORPORATION KYOTO JAPAN	DRAWING NO. KD-84403-A			SHEET 3/3

